



The ExOne Company

**Manufacturing Guidelines for ExOne Metal Infiltrated
Parts**

NH-PSC-GL-006

The ExOne Company

The ExOne Company
127 Industry Boulevard
North Huntingdon, PA 15642
USA

Phone: + 1 877-773-9663
Fax: +1 724-864-9663

Legal Notice

2017 The ExOne Company

The document enclosed is protected by copyright and is the property of The ExOne Company. It may not be used or copied in whole or in part for any purpose other than that for which it is supplied without express authorization of The ExOne Company. This document does not constitute any warranty, expressed or implied.

The ExOne Company reserves the right to alter specifications, performance, capabilities, and presentation of the products covered by this document at any time.

All brand names or product names are trademarks or registered trademarks of their respective companies or organizations.

ExOne Infiltrated Materials

420 Stainless Steel/Bronze

- The ExOne Company 3D Printed 420 Stainless Steel infiltrated with Bronze is a matrix material composed of 60% stainless steel and 40% bronze infiltrant. This material offers good mechanical properties, is available in both an annealed and non-annealed condition, is able to be machined, welded and polished, and offers excellent wear resistance.

COMPOSITION:

Printed Base: Alloy 420 Stainless Steel

Infiltrant: 90% Cu / 10% Sn

316 Stainless Steel/Bronze

- The ExOne Company 3D Printed 316 Stainless Steel infiltrated with Bronze is a matrix material composed of approximately 60% stainless steel and 40% bronze infiltrant. This material offers good mechanical properties and fair corrosion resistance. The material is easily machined, welded and polished.

COMPOSITION:

Printed Base: Alloy 316 Stainless Steel

Infiltrant: 90% Cu / 10% Sn

Tungsten/Bronze

- The ExOne Company 3D Printed Tungsten infiltrated with Bronze is a matrix material composed of approximately 55% tungsten and 45% bronze infiltrant. This material is a versatile high-density shielding material with an excellent tensile strength.

COMPOSITION:

Printed Base: Tungsten

Infiltrant: 90% Cu / 10% Sn

General Considerations

➤ Shrinkage

- Materials have typical shrinkage rates for different cross-sections thicknesses. Design parts with consistent cross sections.
- All overhangs will need to be supported during sintering. Features such as fillets and larger cross sectional thicknesses on supporting structures can help prevent sagging.
 - Please consult your sales representative or Jonathon Alquist for design considerations.

➤ Tolerances

- ExOne attempts to produce parts with the tightest tolerances possible. Typical expected tolerances are within 1% (0.5mm [0.02in] minimum) of a given overall dimension for single part production.
- Tighter tolerances and feature specific quality control are achievable in many situations, such as with high-volume production batches. Please consult your sales representative or Jonathon Alquist for design considerations.

➤ Print Resolution

- Parts smaller than 250 x 400 x 250mm [9.8 x 15.7 x 9.8in]

X and Y:	0.063mm [0.002in]
Z:	0.1mm [0.004in]

Infiltration Geometry (Stilting)

- ExOne application specialists will typically add additional infiltration geometry (stilts) to your part. Stilts are necessary to allow bronze to infiltrate the part. Stilt placement is influenced by part design. A smooth area is required to add stilt geometry. Typically, the larger the part, the larger the required stilt area.
 - Textured surfaces: Stilts need a smooth surface to be placed on.
 - Smooth surface area: Stilts require area of 1.5 x 1.5mm [0.06 x 0.06in] minimum
 - Larger parts require larger suitable stilt area
 - Part will have blemish from stilt removal.
 - ExOne will make every attempt to keep the blemish minimal in an unnoticeable area.

Wall Thickness

➤ The minimum thickness your model should have at main supportive walls:

Part Size	Minimum Wall Thickness
3 – 75mm [0.12 – 3in]	1mm [0.04in]
75 – 150mm [3 – 6in]	1.5mm [0.06in]
150 – 200mm [6 – 8in]	2mm [0.08in]
200 – 300mm [8-12in]	3mm [0.13in]

- Actual minimum thickness vary with actual part geometry.
- The part minimum wall thickness increases as the part size increases.
 - Larger parts require thicker walls.
 - Part minimum dimensions must be met for the part to be printable.

EXAMPLE:

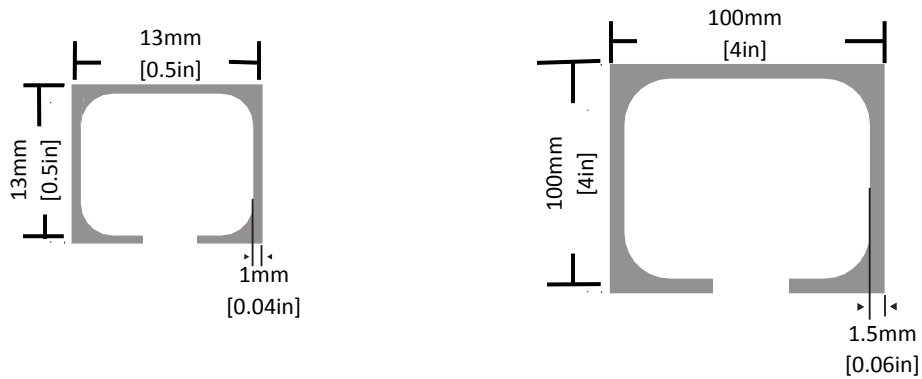

Font & Detail

- Text, numbers and details need to hold a minimum wall dimension of 0.8 mm [0.03 in]
 - Text needs to have a minimum wall thickness of 0.8 mm [0.03 in] (reference “x” below) for the depth, width, and height of the text to appear.

EXAMPLE:

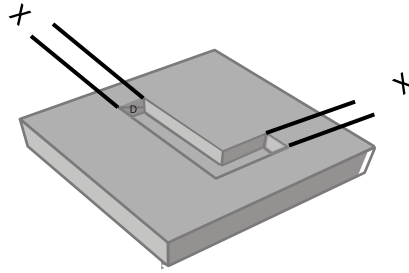

Overhangs

- Overhangs must be designed to not collapse under their own weight.
 - Supports are needed for most features over 25mm [1in]. Fillets help support overhang structures during furnace processing.

EXAMPLE:

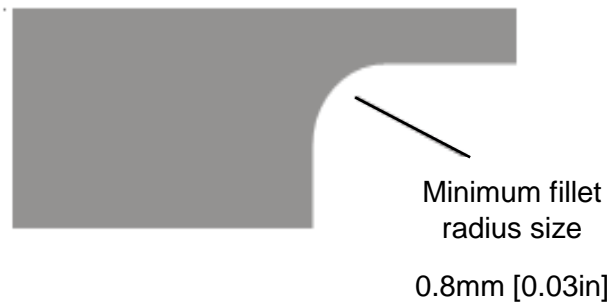

Interior Holes and Cavities

- Interior cavities must have a loose powder drain hole with enough area to allow the powder to be removed during the loose powder removal process.
 - The minimum size of a loose powder removal hole for an interior cavity is approximately 1.5mm [0.06in].
 - When cavities are large or complex, more or larger drain holes may be required.
 - Cavity geometry should determine placement of drain holes. The more centralized the hole to each pocket, the higher the success of the powder removal.
 - The greater the depth of the hole, the larger the required diameter to ensure successful loose powder removal.
 - Please note that parts with liquid holding cavities cannot be plated.

EXAMPLE:

Good Practice

Both cavities have access to a loose powder removal hole

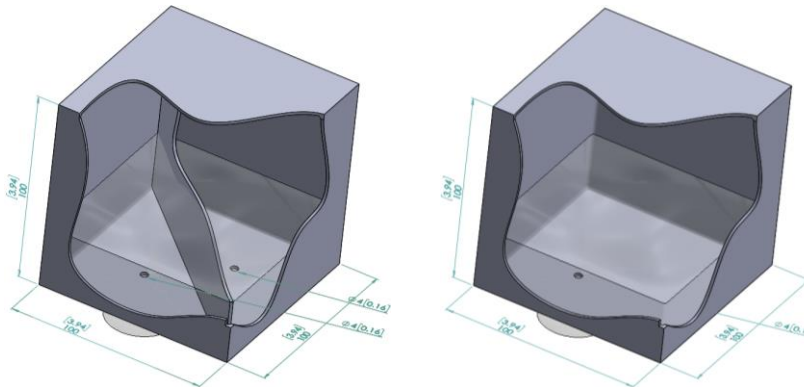

The full cavity has access to a loose powder removal hole

Bad Practice

Only half of the cavity has direct access to a loose powder removal hole

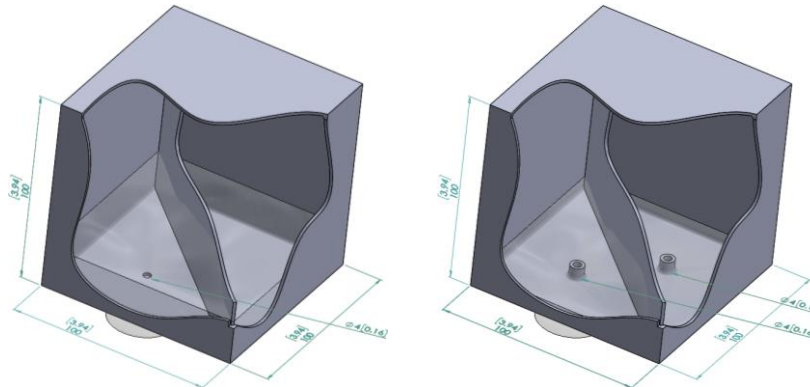

The internal bosses will prevent loose powder from flowing out of the hole

Inside Corners

- Inside corners and sharp intersection should have a filleted edge.
 - Fillet radius size should be approximately equal to the connecting wall thickness.
 - Wall terminations on inside cavities also need to meet the wall thickness minimums.
 - Filleted edges help to prevent distortion and cracking during sintering.

EXAMPLE:

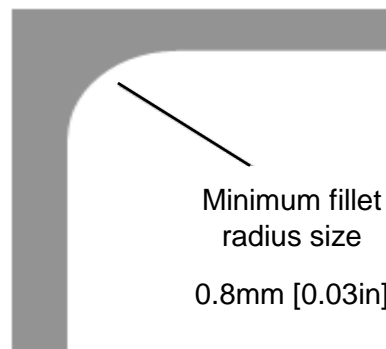

Knife and Pointed Edges

- Fillet all knife edges with a 1mm [0.03in] radius to avoid breakage during depowdering.
- If parts are ordered in a polished finish, sharp edges may become rounded.

EXAMPLE:



Dumbbell Design/Geometry

- Designs or geometries that contain a thin connection between thick walls may distort during sintering.
 - To avoid part distortion, maintain consistent wall thickness.
 - Wall thickness should be as consistent as possible between connecting features.

EXAMPLE:



Moving & Multiple Parts

- ExOne does not typically print moving parts. However, this can be reviewed on a situational basis.
 - If you are interested in printing a moving part, please contact Jonathon.Alquist@exone.com.

EXAMPLE:

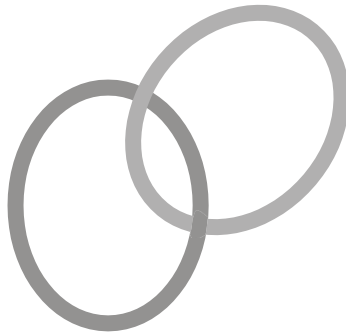

Connected or Sprued Parts

- ExOne only accepts one single part per file.

EXAMPLE:

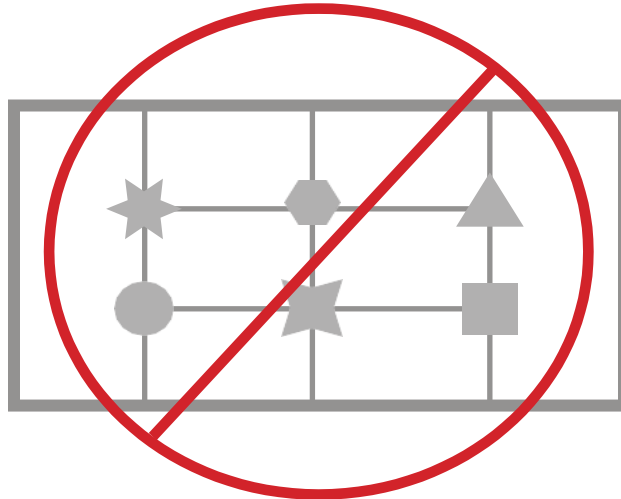

Finishing - Polishing

- ExOne used a high-energy process which tumbles parts in several different polishing media. The part can only be polished where the polishing media can contact and move around the part.
- Maximum part size is 150 x 150 x 75mm [6 x 6 x 3in].
- Not all parts can be polished. ExOne can only determine if polishing is possible once a part has been produced.
- Part geometry can directly affect polishing success or degree. The following geometry types may not polish well.
 - Wire framed parts
 - Fragile parts
 - Thin-walled parts
 - Large flat parts

Finishing – Plating and Patina

- ExOne used a small plating line that requires manual setup and unload.
- Part size maximum is 180 x 180 x 180mm [7 x 7 x 7in].
- In a part contains fluid holding cavities, parts will be unable to be plated.
- ExOne can only determine if plating is possible once a part has been produced. Not all parts can be plated. Parts with liquid holding cavities cannot be plated.
- Plating is purely decorative and will not survive excessive wear.
- Colors may vary.

Sample Finishes



- High Pressure Bead Blast** – The minimum finish that every part receives after stilt removal. It is done using alumina oxide powder in a pressurized controlled cabinet, and is a requirement before all optional finishes.
- Polish (P)** – Requires a high energy tumbling machine with various media, soap and polishing material. It is not suitable for geometrically fragile parts and parts over 7” in diameter and/or parts over 10” long. Please note: this is not a “buffing” operation, and degree of polish is directly related to part geometry. Part is finished with a gloss lacquer.
- Ceramic Blasting (ZB)** – Creates a polish finish to parts that are too geometrically fragile or too large for the high energy polishing machine. It will not create as much shine as the high energy machine. Part is finished with a gloss lacquer.

- **Antique Bronze (AB)** – A light to medium bronze patina that is done through a heat cycle and completed after polishing. Chemicals are not involved in this process. Part is finished with a gloss lacquer.
- **Wheat Penny (WP)** – A medium to dark bronze patina that is done through a heat cycle without polishing, which provides a matte finish. Chemicals are not involved in this process. Part is finished with a matte lacquer.
- **Medieval Pewter (MP)** – A gray to black patina that is done through a heat cycle after polishing. Chemicals are not involved in this process. Part is finished with a gloss lacquer.
- **Damascus Steel (DM)** – A medium to dark black patina that is done through a heat cycle without polishing which provides a matte finish. Chemicals are not involved in this process. Part is finished with a matte lacquer.
- **Nickel Plating (N)** – An electroless nickel plating finish that is very ductile. It is applied on an unpolished part and has a gray to silver finish. Part is finished with a matte lacquer.
- **Nickel Polish Plating (NP)** – An electroless nickel plating finish that is very ductile. It is applied on a polished or ceramic blasted part and has a silver finish. Part is finished with a gloss lacquer.
- **Gold Plating (G)** – An electroless immersion gold plating finish that is very ductile. It is applied over a nickel plated unpolished part and has a matte gold finish. Part is finished with a matte lacquer.
- **Gold Polish Plating (GP)** – An electroless immersion gold plating finish that is very ductile. It is applied over a nickel plated polished or ceramic blasted part and has a polished gold finish. Part is finished with a gloss lacquer.

For more information, please contact:

Jonathon Alquist
Manager of Applications Engineering
Jonathon.Alquist@exone.com

Signatures

Jonathon Alquist

Document ID: NH-PSC-GL-006
Revision: 5
Electronically signed by Jonathon Alquist
Title: Manager, Application Engineering
Date: 2/22/2019 8:52:24 AM
Reason: Approval of Document

Amy Butenko

Document ID: NH-PSC-GL-006
Revision: 5
Electronically signed by Amy Butenko
Title: Quality Manager - North America
Date: 2/22/2019 9:06:07 AM
Reason: Approval of Document